

SERVICE MANUAL

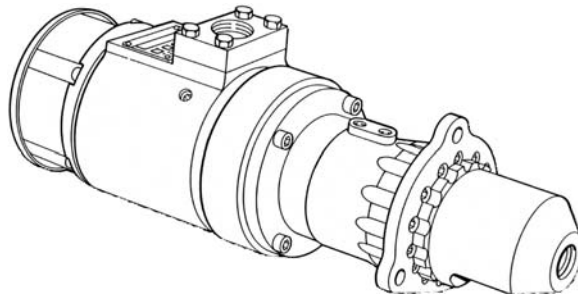

T50-P **TURBO***TWIN* Engine Air Starter



AN 99-447

RJ Mann & Associates Inc.
Engine Controls & Panels/Compressor Parts
860 North 9th Avenue, Brighton, CO 80603
Ph: (303) 659-5139 Fax: (303) 659-5309
www.rjmann.com

TABLE OF CONTENTS

Section	Subject	Page
1.0	Introduction.....	1
2.0	Description of Basic Groups.....	3
3.0	Disassembly.....	5
4.0	Cleaning and Inspection.....	7
5.0	Assembly.....	10
6.0	Parts List.....	13

LIST OF TABLES

Table No.	Title	Page
1	T50 Series Service Tool Kits.....	5
2	Cleaning Materials & Compounds..	7
3	Parts Inspection Check Req.....	8
4	Parts Wear Limits.....	9
5	Torque Values.....	9
6	Materials for Assembly.....	10

LIST OF ILLUSTRATIONS

Figure	Title	Page
1	TDI Turbotwin Nameplate.....	2
2	T50 Series Part Number Coding.....	2
3	Turbine Housing Assembly.....	3
4	Gearbox Housing Assembly.....	4
5	Drive Assembly.....	4
6	Bendix Drive Removal.....	5
7	Turbine Rotor Removal.....	6
8	Turbine Shaft Removal.....	6
9	Nozzle 2 Removal.....	6
10	Gear Teeth Wear Allowance.....	9
11	Turbine Bearing/Shaft Removal.....	10
12	T50 Illustrated Parts List.....	15
13	T50 IPB (S/N: 0610-0994 & After).....	16

SECTION 1.0 INTRODUCTION

1.1 GENERAL INFORMATION

This manual provides information for servicing, disassembly, and re-assembly of the TDI Turbotwin T50-P air starter. If there are questions not answered by this manual, please contact your local TDI distributor or dealer for assistance. Illustrations and exploded views are provided to aid in disassembly and re-assembly.

The TDI Turbotwin T50-P engine air starter is specially designed for starting today's automated, low-emission engines. The Turbotwin uses aerodynamic speed control, allowing for cranking torque throughout the start cycle.

The Turbotwin T50-P air starter is suited to operate within a wide range of inlet pressures and ambient temperatures. This starter is designed for operation on compressed air and natural gas.

The robust turbine motor design in the Turbotwin T50-P air starter has no rubbing parts and, therefore, is tolerant of hard and liquid contamination in the supply to the starter.

As with all TDI air starter products, there are no rubbing parts so there is no lubrication required. This eliminates failures due to lubricator problems, the expense of installing and maintaining the system, and the messy and hazardous oil film around the starter exhaust. The starter is factory grease packed for the life of the starter so it requires no maintenance.

Please review the rest of this manual before attempting to service the TDI Turbotwin T50-P air starter.

1.2 WARNINGS, CAUTIONS, & NOTES

Throughout this manual, certain types of information will be highlighted for your attention:

WARNING - used where injury to personnel or damage to equipment is possible.

CAUTION - used where there is the possibility of damage to equipment.

NOTE - use to point out special interest information.

1.3 DESCRIPTION OF OPERATION

The Turbotwin T50-P air starter is powered by a two stage axial flow turbine coupled to a simple planetary gear reduction set. The T50-P air starter incorporates a pre-engaged drive coupled to the starter gearbox drive train to provide a means of disengaging the pinion from the engine's ring gear.

The high horsepower of the turbine air motor combined with the planetary gear speed reducer results in a very efficient and compact unit. The Turbotwin T50-P air starters can be used over a wide range of drive pressures from 40 psig (2.7 BAR) to 120 psig (8 BAR) and are suitable for operation on compressed air and natural gas.

The T50-P weighs approximately 34 pounds (15 KG) and is capable of delivering over 45 HP (33.6 kW) of cranking power at the maximum pressure of 120 psig (8 BAR).

1.4 INSTALLATION AND SERVICE

It is important to properly install and operate the TDI T50-P air starter to receive the full benefits of the turbine drive advantages. It must be installed in accordance with the instructions provided by Tech Development (TDI).

WARNING

Failure to properly install the starter or failure to operate it according to instructions provided by TDI may result in damage to the starter or engine, or cause personal injury. **DO NOT OPERATE THIS STARTER UNLESS IT IS PROPERLY ATTACHED TO AN ENGINE.**

Repair technicians or service organizations without turbine starter experience should not attempt to repair this starter until they receive factory approved training from TDI, or its representatives. Proper operation and repair of your TDI Turbotwin will assure continuous reliability and superior performance for many years.

1.5 NAMEPLATE INFORMATION

The nameplate located on the turbine housing provides important information regarding the construction of your T50-P air starter, refer to *Figure 1*. The part number coding explanation, refer to *Figure 2*, can help you when talking to your distributor.

NOTE

You should always have the starter's Part Number, Serial Number, Operating Pressure, and Direction of Rotation information before calling your TDI distributor or dealer.

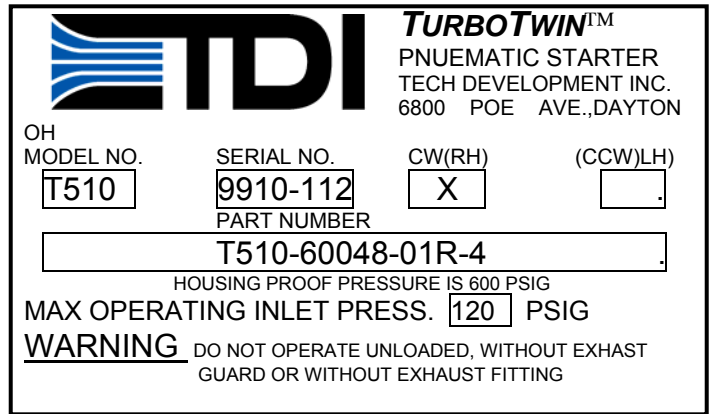

Figure 1. TDI TURBOTWIN Nameplate

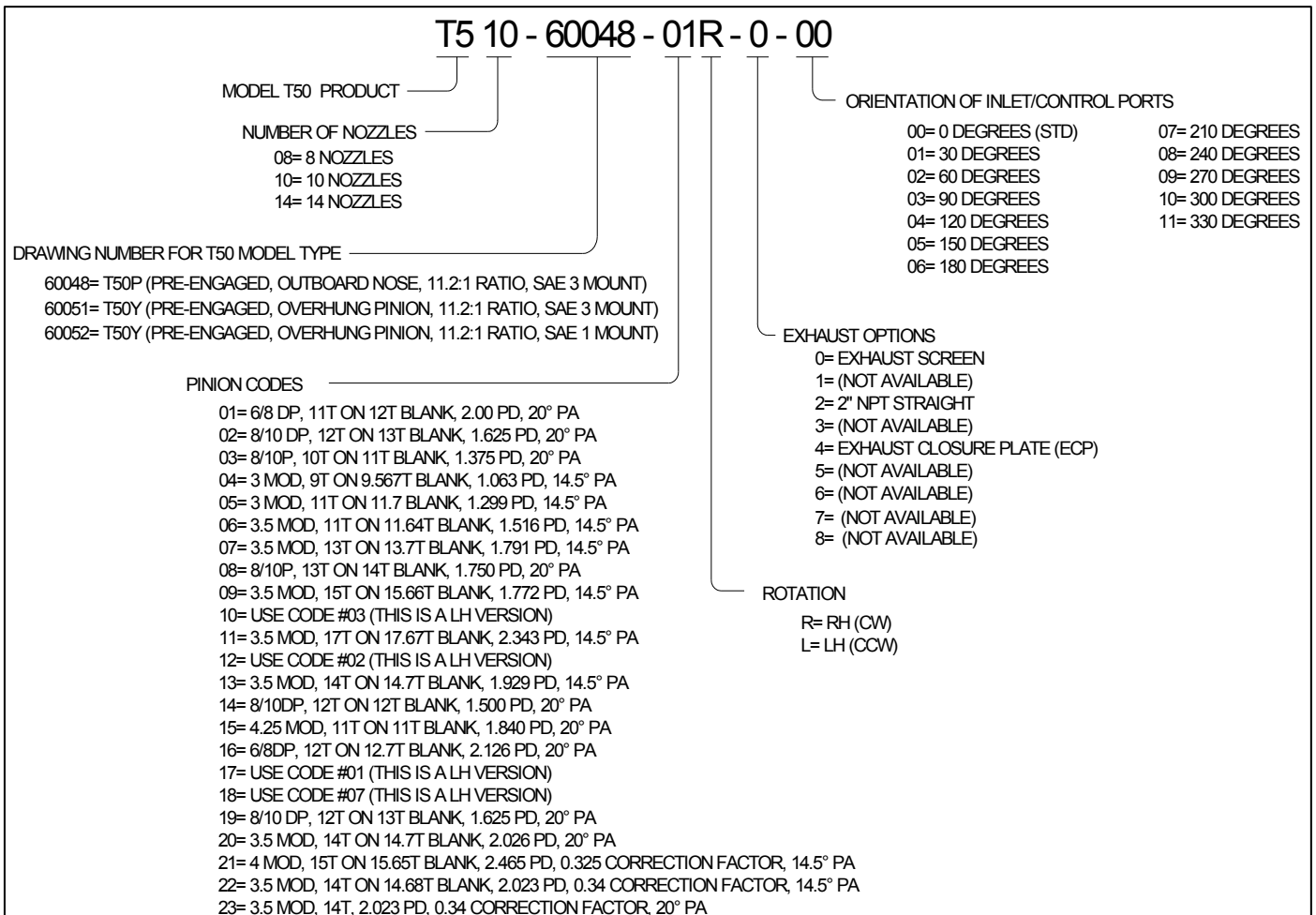

Figure 2. T50 Series Nameplate Identification

SECTION 2.0 DESCRIPTION OF BASIC GROUPS

2.1 GENERAL

The TDI Turbotwin T50-P air starter is a lightweight, compact unit driven by a two stage turbine air motor. The starter is composed of three basic assembly groups: Turbine Housing Assembly, Gearbox Housing Assembly, and Bendix Drive Assembly.

2.2 TURBINE HOUSING ASSEMBLY

The Turbine housing assembly, refer to figure 3, consists of a stage one (23) and a stage two (13) turbine rotor mounted on sun gear shaft (29). The front bearing (15) is secured by a retainer plate (27) and the aft bearing is pre-load by a spring washer (16).

The ring gear (31) is installed between the turbine assembly (26) and the gearbox housing (41) and secured by four screws (42).

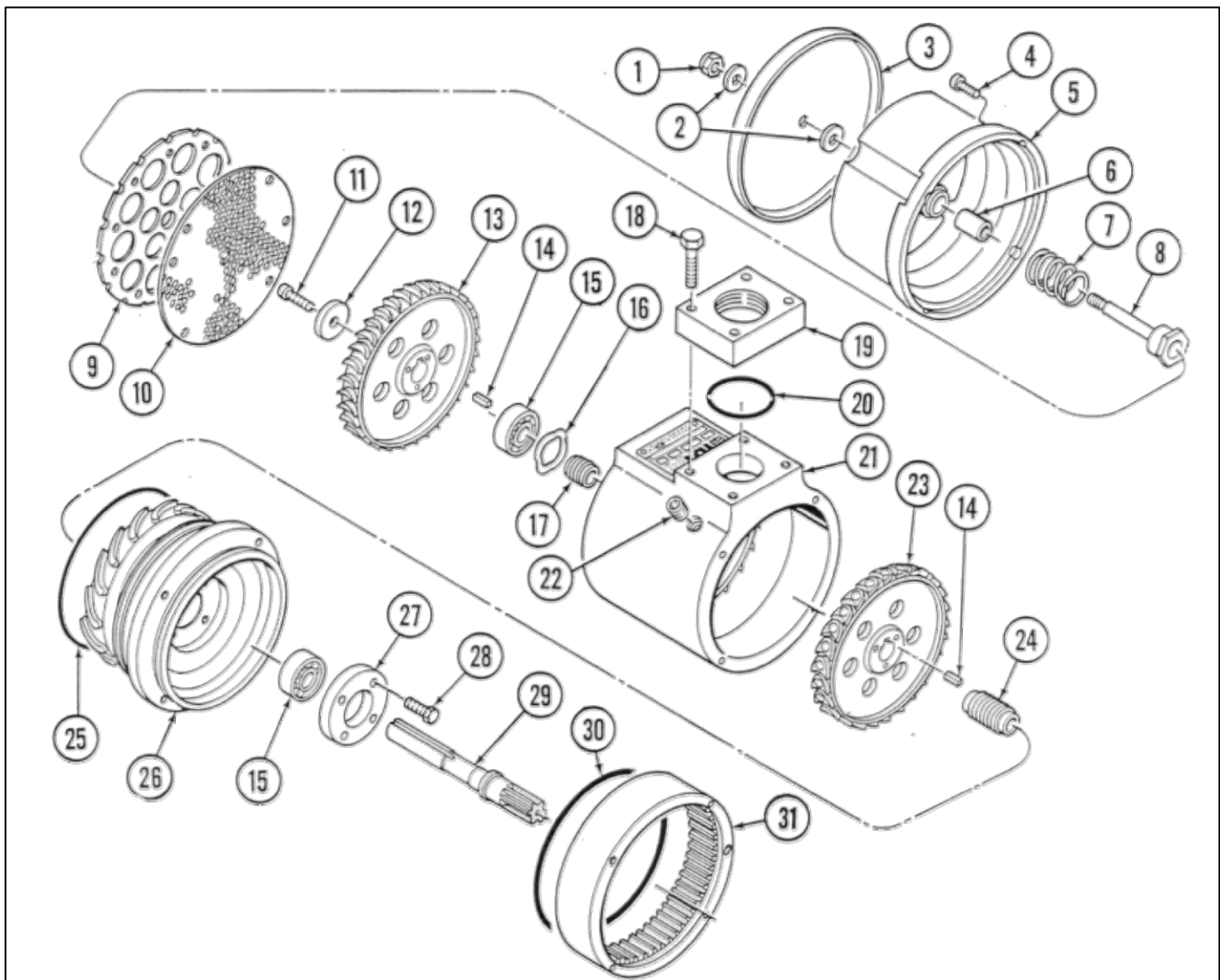

Figure 3. Turbine Housing Assembly

2.3 GEARBOX HOUSING ASSEMBLY

The gearbox housing assembly, refer to figure 4, consists of a planet gear carrier and output shaft (32), three planet gears (36), needle bearings (37), spacers (35), and planet shafts (34).

The carrier shaft (32) is mounted on a single bearing (38) in the gearbox housing (41). The retainer ring (48) secures the carrier shaft in the gearbox housing. The bearing housing (44) and pre-engaged piston (50) are installed in the gearbox housing (31).

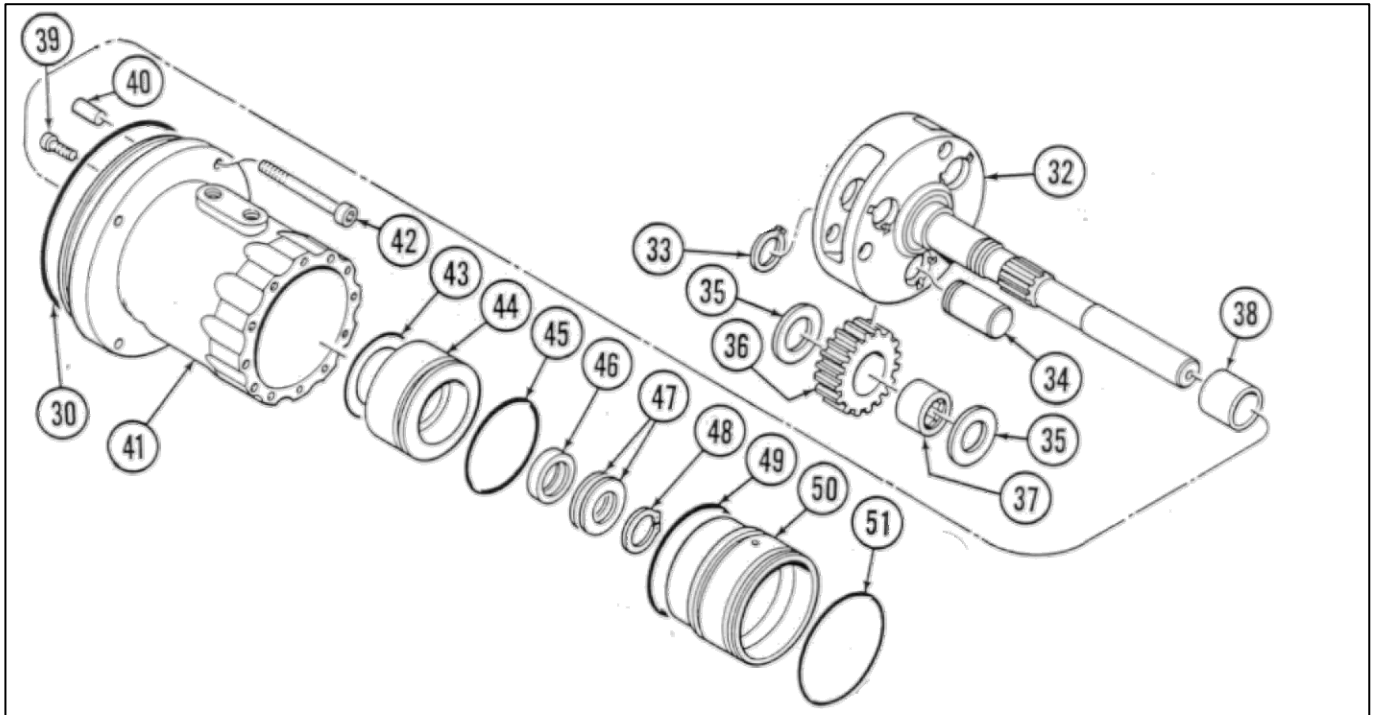

Figure 4. Gearbox Housing Assembly

2.4 DRIVE ASSEMBLY

The drive assembly, refer to figure 5, consists of a pre-engagement drive (53) and drive housing (56). Twelve screws (57) secure the drive housing to the gearbox housing.

The front end of the carrier shaft (32) is mounted in a needle bearing (58), which is installed in the nose of the drive housing.

Split rings (52) and a return spring (54) aid in the disengagement of the pinion from the engine's ring gear.

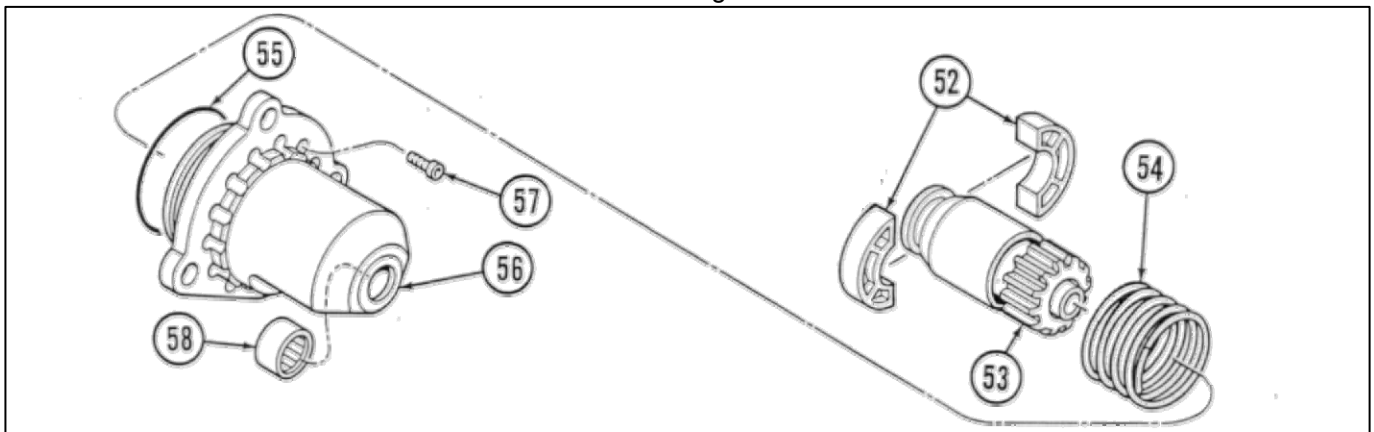

Figure 5. Drive Assembly

SECTION 3.0 DISASSEMBLY

3.1 GENERAL

Always mark adjacent parts on the starter; Nozzle 2/ Containment Ring (21), Turbine Housing (26), Gearbox Housing (41), and Drive Housing (56) so these parts can be located in the same relative position when the starter is reassembled.

Do not disassemble the starter any further than necessary to replace a worn or damaged part

Always have a complete overhaul kit on hand before starting any overall of a Turbotwin T50-Pair starter. Never use old screws, seals, and o-rings.

The tools listed in *Table 1* are suggested for use by technicians servicing the Turbotwin T50-P air starter. The best results can be expected when these tools are used.

TOOL DESCRIPTION	TDI/PN
Spanner Wrench	2-27272
Stage 2 Rotor Puller Tool	52-20076
Tool, Turbine Bearing	45-25294
Tool, Bearing/Seal	2-26943
Tool, Seal Positioning	45-25316

Table 1. T50 Series Service Tools (P/N: T50-28570)

3.2 DRIVE HOUSING

3.2.1 Removal of Drive Housing

Mark position of drive pinion opening relative to gearbox housing for reference during re-assembly.

Remove the 12 screws (57) and pull drive housing (56) from gearbox housing (41). If drive housing is too tight, tap it with a mallet to loosen.

3.2.2 Removal of Drive

Remove return spring (54) and pull drive (53) from carrier shaft assembly (32).

Remove split rings (52) from drive assembly.

3.2.3 Drive Bearing Removal

Press needle bearing (58) from drive housing (56) using press tool.

3.3 GEARBOX HOUSING

3.3.1 Removal of Gearbox Housing

Remove the four screws (42) and separate the gearbox assembly from the turbine assembly. If the gearbox is too tight, tap it with a mallet to loosen.

3.3.2 Gearbox Disassembly

Remove snap ring (48) and two thrust washers (47) from carrier shaft (32).

Apply pressure to the carrier shaft to remove it from the gearbox housing.

Remove four screws (39) and press the bearing housing/pre-engaged piston assembly (44,50) from the gearbox housing.

Hand press bearing housing (44) out of pre-engaged piston (50).

3.3.3 Carrier Shaft/Planet Gear Disassembly

Remove snap ring (33) from planet shaft (34) and push shaft through holes in assembly. Refer to figure 6.

Slide the planet gear (36) out from the carrier shaft and remove the two spacers (35).

Press the needle bearing (37) from the planet gear (36) to remove it.

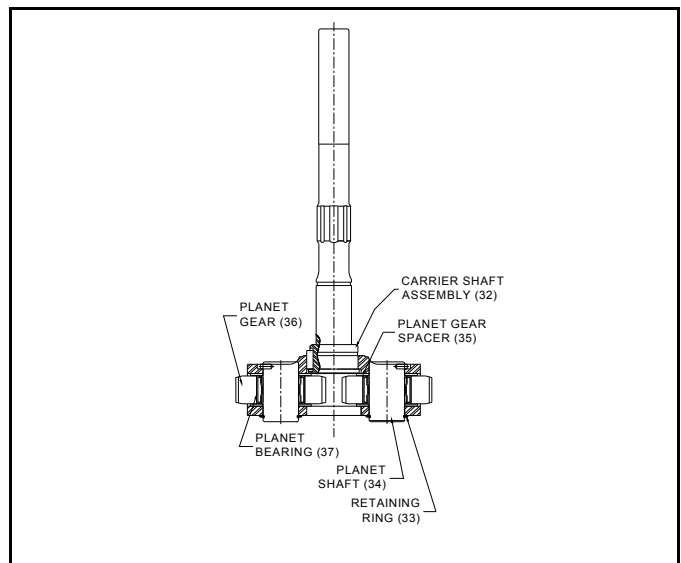

Figure 6. Carrier Shaft Disassembly

3.4 TURBINE HOUSING

3.4.1 Stage 2 Rotor Removal

Remove four screws (4), ECP assembly (5), exhaust support (9), and exhaust guard (10). Units with an exhaust screen (no ECP) will utilize 8 screws.

Hold the stage 2 rotor (13) and remove the turbine screw (11) and washer (12).

NOTE

Secure the sun gear (29) in a soft jaw vise when removing turbine screw.

Install rotor puller tool P/N 52-20076 and remove the stage 2 rotor as shown in figure 7.

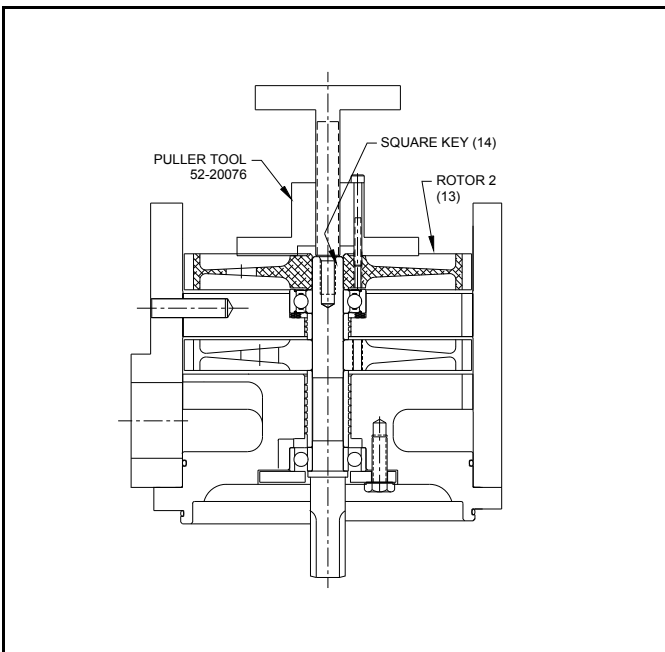

Figure 7. Turbine Rotor Removal

Remove the square key (14) from turbine shaft (29).

3.4.2 Turbine Housing Disassembly

Place the turbine on a firm surface with the sun gear end facing up.

Remove three screws (28) and bearing retainer plate (27) from turbine housing (26). Units with S/N: **0610-0994** and after will utilize four screws.

With the exhaust end facing up, press turbine shaft (29) through turbine housing (26) as shown in figure 8. Remove labyrinth (24) from turbine shaft.

Remove the aft bearing (15), wavy washers (16), and labyrinth (17) from nozzle 2.

Install three screws (42) removed from the gearbox housing into the jack holes on the turbine housing (26) as shown in figure 9.

Turn the screws in sequence until the turbine housing (26) is completely removed from the nozzle 2 (21).

Remove the stage 1 rotor (23) and square key (14).

Press turbine shaft (29) through forward bearing (15) to remove bearing from shaft.

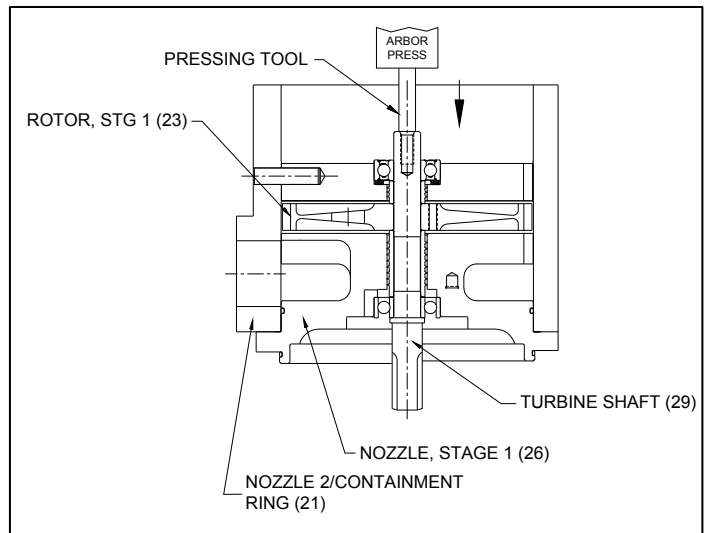

Figure 8. Turbine Shaft Removal

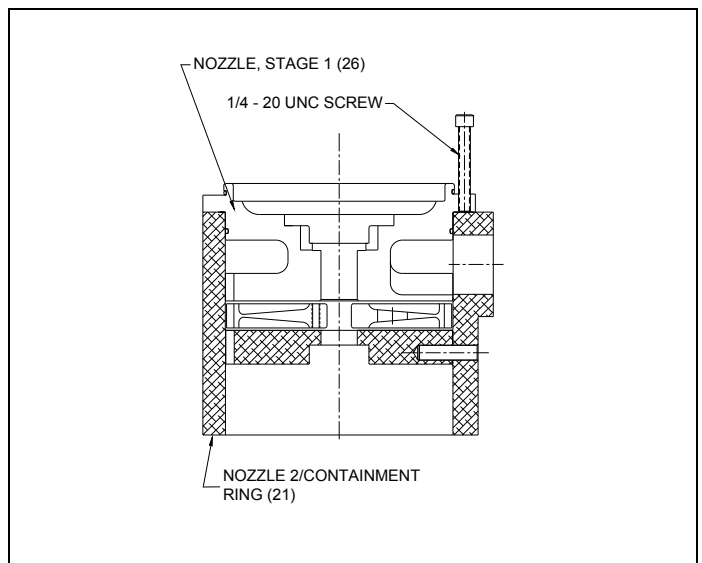

Figure 9. Nozzle 2 Removal

SECTION 4.0 CLEANING and INSPECTION

4.1 CLEANING

Degrease all metal parts, except bearings, using a commercially approved solvent. Refer to *Table 2*.

NOTE

Never wash bendix assembly or bearings in cleaning solvents. It is recommended bearings be replaced with new parts.

Clean aluminum parts using the solutions per *Table 2*; soak for 5 minutes. Remove parts, rinse in hot water, and dry thoroughly.

Clean corroded steel parts with a commercially approved stripper.

Clean corroded aluminum parts by cleaning as stated above and then immerse the parts in chromic-nitric-phosphoric acid pickle solution per *Table 2*. Rinse in hot water and dry thoroughly.

MATERIAL or COMPOUND	MANUFACTURER
Degreasing Solvent (Trichloroethylene) (O-T-634)	Commercially Available
Acetone	Commercially Available
Aluminum Cleaning Solution	Diversey Corp., 212 W. Monroe, Chicago, IL 60606 Dissolve 5 oz of Diversey 808 per gallon of water at 155°- 165°F.
Steel Cleaner - Rust & Corrosion	Oakite Products Corp., 50 Valley Rd., Berkeley Heights, NJ 07992 Mix 3-5 lb. of Oakite rust Stripper per gallon of water; use at 160°- 180°F.
Chromic-Nitric-Phosphoric Acid Pickle Solution	Mix 8lb. of chromic acid, 1.9 gal. of phosphoric acid, 1.5 gal. of nitric acid with enough water to make a total of 10 gal. of solution.
WARNING Follow all instructions provided with the MSDS sheets on the materials and compounds listed above.	

Table 2. Cleaning Materials and Compounds

4.2 INSPECTION

Use *Table 3* as a guide to check for acceptable condition of the parts listed.

Check all threaded parts for galled, crossed stripped, or broken threads.

Check all parts for cracks, corrosion, distortion, scoring, or general damage.

Check all bearing bores for wear.

Check gear teeth and turbine housing ring gear for wear. In general, visually check for spalling, fretting, surface flaking, chipping, splitting, and corrosion. If wear is apparent, check the gear teeth dimensions in accordance with *Table 4*. Nicks and dents that cannot be felt with a .020 inch radius scribe are acceptable.

Part Description	Check For	Requirements (Defective Parts Must Be Replaced)
Drive	Worn loose or missing parts	Defective unit to be replaced. Use figure 10 as a guideline for acceptable pinion wear.
Drive Housing	Cracks and breakage	Cracks are not acceptable
Planet Gear	Cracked, chipped, worn, or galled teeth.	Wear must not exceed limits per table 4. There shall be no evidence of excessive wear.
Carrier Shaft	Cracks, scoring or raised metal in planet shaft holes and keyways. Integrity of knurl/keyed connection.	Deformation of metal (smearing) in planet pin holes & keyways not acceptable. Scoring on bearing diameter not to exceed .005" depth. Wear must not exceed limits per Table 4.
Planet Pins	Wear grooves or flat spots	Wear grooves in flat spots not permitted. Wear must not exceed limits per Table 4.
Washers	Wear grooves	Wear must not exceed limits per Table 4.
Gearbox Housing	Cracks and Breakage	Cracks and breakage not acceptable.
Sungear/Turbine Shaft	Cracks, scoring, wear grooves, chipped or broken gear- teeth, galling or scoring on bearing surface of shaft. Raised metal on the keyway.	Wear must not exceed limits per Table 4.
Spacers	Parallelism of end surfaces	Ends must be parallel within 0.0005".
Turbine Housing	Cracks and breakage	Cracks and breakage are not acceptable. Minor surface damage is permitted if function is not impaired.
Ring Gear	Cracks, worn, chipped, or broken gear teeth.	Wear must not exceed limits per Table 4.
Needle Bearings	Freedom of needle rollers	Replace bearings
Ball bearings	Freedom of rotation without excessive play between races	Replace bearings
Containment Ring/ Nozzle	Corrosion, erosion, cracks and broken nozzle edges.	Cracks and breakage are not acceptable. Minor surface damage is permitted if function is not impaired.
Turbine Rotors	Corrosion, erosion, cracks and broken edges. Bore and key way wear	Minor tip rub is permitted if function is not impaired. Wear is not permitted.

Table 3. Parts Inspection Check Requirements

PART DESCRIPTION	LIMIT, Inches
Ring gear / Turbine Housing Internal measurement between two .072" diameter pins.	4.6655 max.
Sun Gear / Turbine Shaft Bearing diameter External measurement over two .072 diameter pins. 11.2:1	.5566 min
Planet Gear External measurement over two .085" diameter pins. 11.2:1	2.2217 min

Table 4. Parts Wear Limits

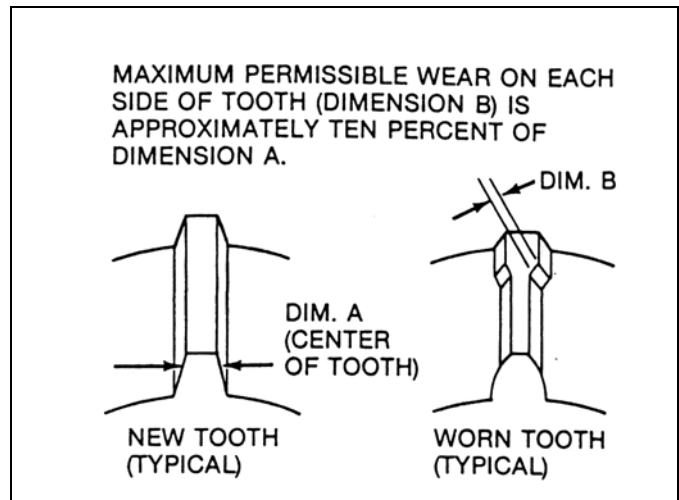

Figure 10. Gear Teeth Wear Allowances

ITEM NUMBER *	TORQUE	
	In-lbs	Nm
4 (Screw)	190	21
11 (Screw)	220	25
18 (Screw)	75	8
28 (Screw)	113	13
39 (Screw)	81	9
42 (Screw)	190	21
57 (Screw)	190	21
* Refer to section 6 for part number identification.		

Table 5. Torque Values

SECTION 5.0 ASSEMBLY

5.1 GENERAL INFORMATION

The tools listed in *Table 1* are suggested for use by technicians servicing the Turbotwin T50-P air starter. The best results can be expected when these tools are used.

CAUTION

Replace all screws, o-rings, lip seals, and bearings. These parts are included in the overhaul kit shown in the Parts List, Section 6.0.

NOTE

Always press the inner race of a ball bearing when installing a bearing onto a shaft. Always press the outer race of a ball bearing when installing into a housing. **DO NOT LOAD BEARING BALLS.**

Lubricate all o-rings with petroleum jelly or Parker O-ring Lube before assembly. Refer to *Table 5* for a list of materials to be used during assembly.

MATERIALS	SOURCE
Petroleum Jelly	Commercially Available
Parker-O-Ring Lube	Commercially Available
Aeroshell #6 Grease	Commercially Available
Loctite RC290	Commercially Available
Grease, gearbox	TDI P/N 9-94121-001

Table 6. Materials for Assembly

5.2 TURBINE HOUSING

5.2.1 TURBINE BEARING INSTALLATION

Press the turbine bearing (15) onto the turbine shaft (29) until seated.

Press the turbine bearing/shaft assembly (15,29) into the turbine housing (26). Use press tool P/N 2-26943 if required per figure 11. Do not press on the end of the shaft because the load could damage the bearing balls.

Install the bearing retainer (27) into the turbine housing (26) and secure with three screws (28) Torque to 75 in-lbs. Units with S/N: **0610-0994** and after will utilize four screws.

Install o-ring (25) onto turbine housing (20).

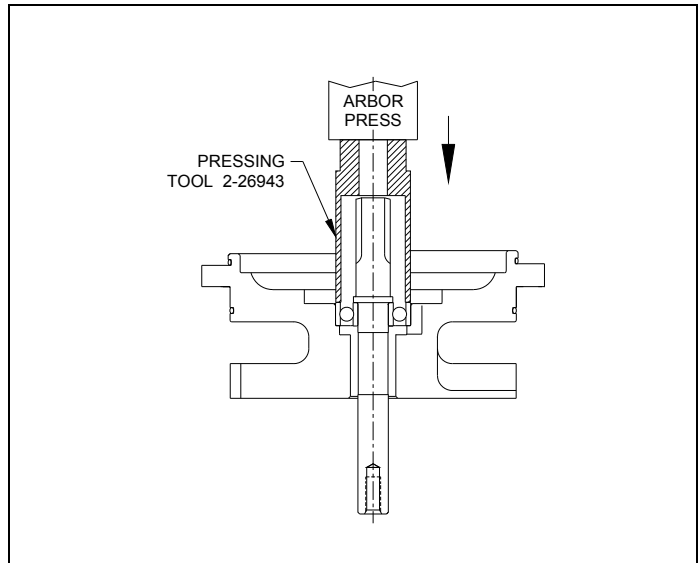

Figure 11. Turbine Bearing / Shaft Installation

5.2.2 ROTOR 1 INSTALLATION

Turn the turbine nozzle over (exhaust end up) and install the labyrinth (18) onto the shaft. For units with **0610-0994** and after press lip seal P/N: 2-26179 onto spacer P/N: 9-93114 and press lip seal with lips facing up into aft end of nozzle 1.

Press the square key (14) into the keyway of turbine shaft (29) until seated.

Install stage 1 rotor (23) by sliding over turbine shaft (29), while simultaneously aligning the key with the keyway in the rotor.

5.2.3 STAGE 2 NOZLE INSTALLATION

Install turbine housing (26) into nozzle 2 containment housing (21).

NOTE

The air inlet port on nozzle 2 must be aligned with the casting indentation on the turbine housing.

5.2.4 ROTOR 2 INSTALLATION

Turn the turbine nozzle over (exhaust end up) and install the labyrinth (17) onto the shaft.

Install pre-load springs (16) into bearing bore of nozzle 2 containment housing (21).

Apply a light coating of oil to the bearing bore in the Nozzle Containment Assembly and press the turbine bearing (15) over the turbine shaft and into the bearing bore using press tool P/N. 2-26943

Insert key (14) into turbine shaft keyway and install stage 2 rotor (13) onto shaft while simultaneously aligning the key with the keyway in the rotor.

Secure stage 2 rotor with rotor washer (12) and rotor screw (11). Torque to 220 in-lb.

Turn turbine housing over and install o-ring (30) into the o-ring groove on the turbine housing (26).

Install plug (22) into Nozzle Containment Assembly.

Install the ring gear (31) onto turbine housing with the dowel pin hole facing up.

Install dowel pin (40) into dowel pin hole in ring rear (31).

5.3 GEAR BOX ASSEMBLY

5.3.1 PLANETARY GEAR CARRIER ASSEMBLY

Press needle bearings (37) into planet gears (36) using arbor press. The bearing ID stamping must be against pressing tool. The bearing should be centered between gear faces.

Place thrust washer (35) on each side of planet gear (36) and install into carrier shaft (32) slot.

Install planet shaft (34) into the carrier and secure with snap ring (33). Be sure the anti-rotation pin is inserted into the slot on the carrier shaft.

5.3.2 CARRIER SHAFT INSTALLATION

Install o-ring (43) into forward side of gearbox housing (41).

If removed, press gearbox bushing (38) into bearing housing (44).

Press the lip seal (46) into the forward side of the bearing housing (44) until seated using press tool P/N: 2-26943.

Install o-ring (43) into the groove on the bearing housing (44).

NOTE

Apply a small amount of Aeroshell grease to the outer wall of the bearing hub and the inside wall of the gearbox housing to allow for easier housing installation.

Install the bearing housing assembly (38,44,46) in the forward side of the gearbox housing (41) and secure with four screws (39). Torque to 81 In-Lbs.

Install two o-rings (49,51) into the grooves on the pre-engaged piston (50).

NOTE

Apply a small amount of Aeroshell # 6 grease to the inner and inner walls of the pre-engaged piston to allow for easier installation.

Press pre-engaged piston into the forward side of the gearbox housing and remove any excess grease from gearbox housing.

Install lip seal tool PN: 45-25316 into forward side of gearbox housing (41) placing tapered end of tool into lip seal (46).

Install gearbox housing onto carrier shaft and place two thrust washers (47) on carrier shaft (32). Secure with snap ring (48) using snap ring pliers.

5.3.3 DRIVE INSTALLATION

Apply a small amount of Aeroshell # 6 grease to split rings (52) and install split rings onto drive assembly (53).

Install o-ring (55) onto drive housing (56)

Install the drive assembly (53) onto carrier shaft and place return spring (54) over drive assembly.

5.3.4 NOSE BEARING INSTALLATION

Place the drive housing onto arbor press with the nose of drive facing down.

Press needle bearing (58) into drive housing (56) using arbor press. The bearing ID stamping must be against pressing tool. Do not press bearing tight against the

drive housing shoulder. In addition, be sure stamped end is beneath shoulder of bearing bore.

5.4 FINAL ASSEMBLY

Apply o-ring grease to o-ring (30) and install onto gearbox housing.

Apply liberal amounts of grease (100 grams) to planet gears (36), turbine shaft sun gear (29) and ring gear (31).

Temporarily install one screw (42) into ring gear (31) to prevent it from rotating while applying grease.

Align gearbox assembly with turbine assembly and fasten together with four screws (42).

Install drive housing (56) onto gearbox housing (41) and secure with twelve screws (57). Torque to 150 in-lb.

Install exhaust closure plate assembly using four screws (4). Torque to 150 in-lb.

SECTION 6.0 PARTS LIST

The components illustrated and/or described in this section are for the Turbotwin T50-P air starter. When rebuilding a T50-P air starter, it is recommended to purchase and completely install the appropriate service kit(s).

T50-P ILLUSTRATED PARTS LIST				
ITEM #	DESCRIPTION	PART NUMBER	QTY.	Overhaul Kit T50P-28533-001
1	Nut, Hex	9-92155-06	1	✓
2	Washer, Flat	9-93018-011	2	
3	Plate, Baffle	2-20192	1	
4	Screw	14F-25020-014	8	✓
5	Housing, Exhaust Cover	2-28369	1	
6	Bushing	9-91436	1	
7	Spring, Compression	9-90408-016	1	
8	Post	2-27223	1	
9	Exhaust Support	2-27475	1	
10	Exhaust Guard	2-28380	1	
11	Screw, Rotor Attachment	14F-25028-012	1	✓
12	Rotor Washer	9-93047	1	
13	Stage 2 Rotor	2-28410	1	
14	Square Key (1/8")	9-90220-050	2	✓
15	Turbine Bearing	9-91224	2	✓
16	Bearing Pre-Load Spring	9-90439	2	✓
17	Spacer / Labyrinth	2-28445	1	✓
18	Screw	71F-31218-020	4	
19	Inlet Flange	2-28360	1	
20	O-Ring	9-90001-031	1	✓
21	Containment, Nozzle 2, RH	2-28359-00R	1	
21	Containment, Nozzle 2, LH	2-28359-00L	1	
22	Hollow Hex Plug	9-93501-002	1	
23	Stage 1 Rotor	2-27225	1	
24	Spacer/Labyrinth	2-28444	1	✓
25	O-Ring	9-90001-047	1	✓
26	Turbine Hsg. / Stage 1 (10 Noz. RH)	2-28354-10R	1	
26	Turbine Hsg. / Stage 1 (10 Noz. LH)	2-28354-10L	1	
26	Turbine Hsg. / Stage 1 (14 Noz. RH)	2-28354-14R	1	
26	Turbine Hsg. / Stage 1 (14 Noz. LH)	2-28354-14L	1	
27	Bearing Retainer	2-28446	1	
28	Screw	71F-25020-012	3	✓
29	Turbine Shaft 11.2:1)	2-28339	1	
30	O-Ring	9-90001-047	2	✓

ITEM #	DESCRIPTION	PART NUMBER	QTY.	Overhaul Kit T50P-28533-001
31	Ring Gear	2-28430	1	
32	Carrier Shaft Assembly	2-28358	1	
33	Retaining Ring	9-92001-001	3	
34	Planet Shaft	2P-20182	3	
35	Planet Gear Spacer	9-93004	6	✓
36	Planet Gear (11.2:1)	2-28316	3	
37	Planet Bearing	9-91004-001	3	✓
38	Bushing	9-91405	1	✓
39	Screw	14F-19024-012	4	✓
40	Dowel Pin	9-91502-007-0-10	1	
41	Gearbox Housing	2-28352	1	
42	Screw	14F-25020-044	4	✓
43	O-Ring	9-90001-035	1	✓
44	Bearing Housing	2-24114	1	
45	O-Ring	9-90002-331	1	✓
46	Lip Seal	2-23810	1	✓
47	Thrust Washers	9-93085	2	✓
48	Retaining Ring	9-92001-025	1	✓
49	O-Ring	9-90002-336	1	✓
50	Pre-engage Piston	2-24644-001	1	
51	O-Ring	9-90002-234	1	✓
52	Split Rings	2-23419	2	✓
53	Drive, 6/8P, 11T, RH	2-22954	1	
53	Drive, 6/8P, 11T, LH	2-22956	1	
53	Drive, 3.5MOD, 14T, RH	2-26816	1	
53	Drive, 3.5MOD, 14T, LH	2-25933	1	
53	Drive, 6/8P, 12T, RH	2-26143-001	1	
54	Return Spring	9-90422	1	
55	O-Ring	9-90001-041	1	✓
56	Drive Housing (6/8P)	2-24127-007	1	
57	Screw	14F-25020-012	12	✓
58	Nose Bearing (6/8P)	9-91408	1	✓

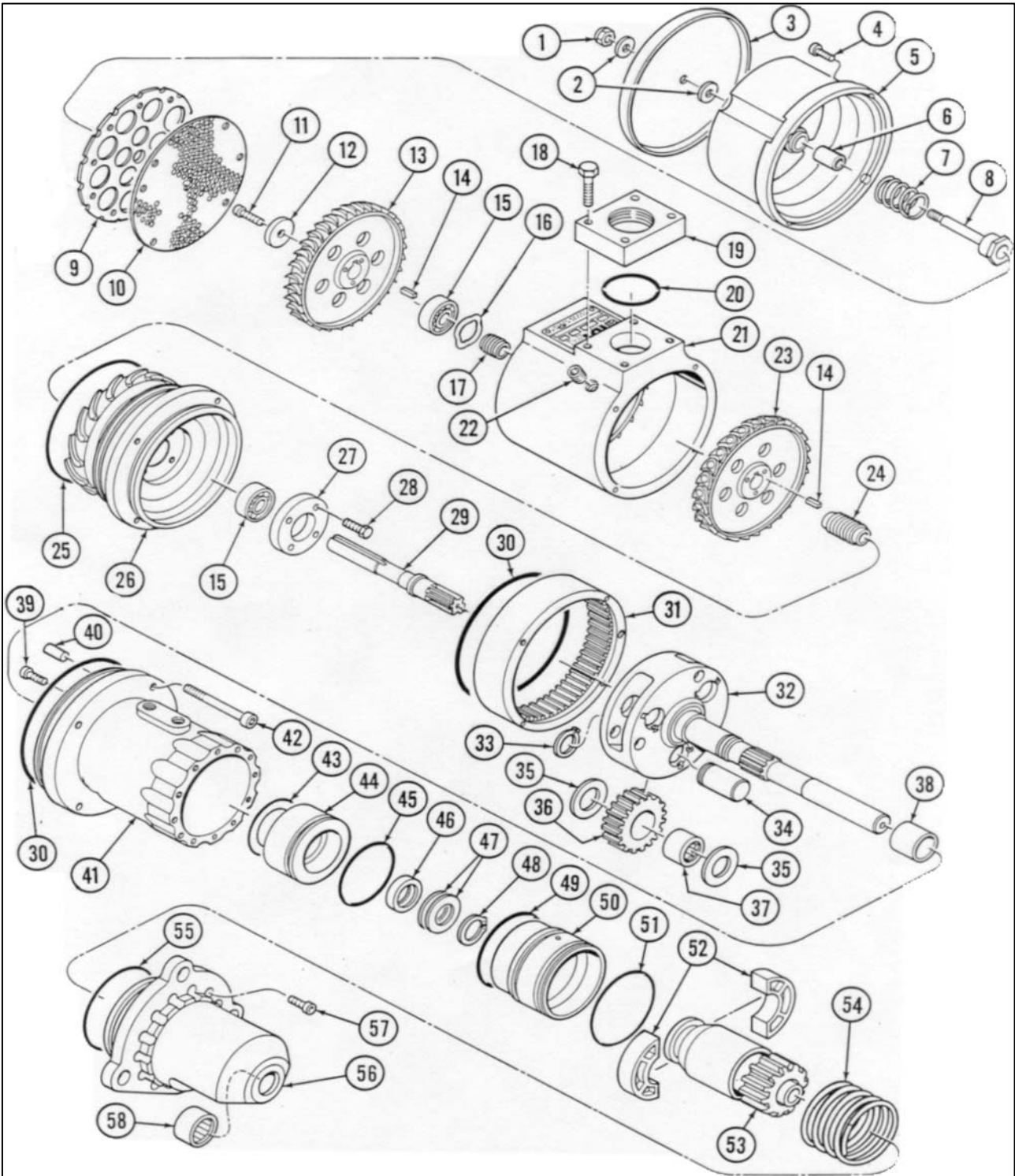

Figure 12. T50-P Illustrated Parts List

T50-P TURBINE ASSEMBLY (effective serial #: 0610-0994)				
ITEM #	DESCRIPTION	PART NUMBER	QTY	Overhaul Kit T50P-28533-001
24	Bearing Spacer	9-93114	1	√
24A	Lip Seal	2-26719	1	√
26	Turbine Hsg. / Stage 1 (8 Noz. RH)	2-28354-08R	1	
26	Turbine Hsg. / Stage 1 (8 Noz. LH)	2-28354-08L	1	
26	Turbine Hsg. / Stage 1 (10 Noz. RH)	2-28354-10R	1	
26	Turbine Hsg. / Stage 1 (10 Noz. LH)	2-28354-10L	1	
26	Turbine Hsg. / Stage 1 (14 Noz. RH)	2-28354-14R	1	
26	Turbine Hsg. / Stage 1 (14 Noz. LH)	2-28354-14L	1	
27	Bearing Retainer	2-27406	1	
28	Screw	71F-25020-012	4	√

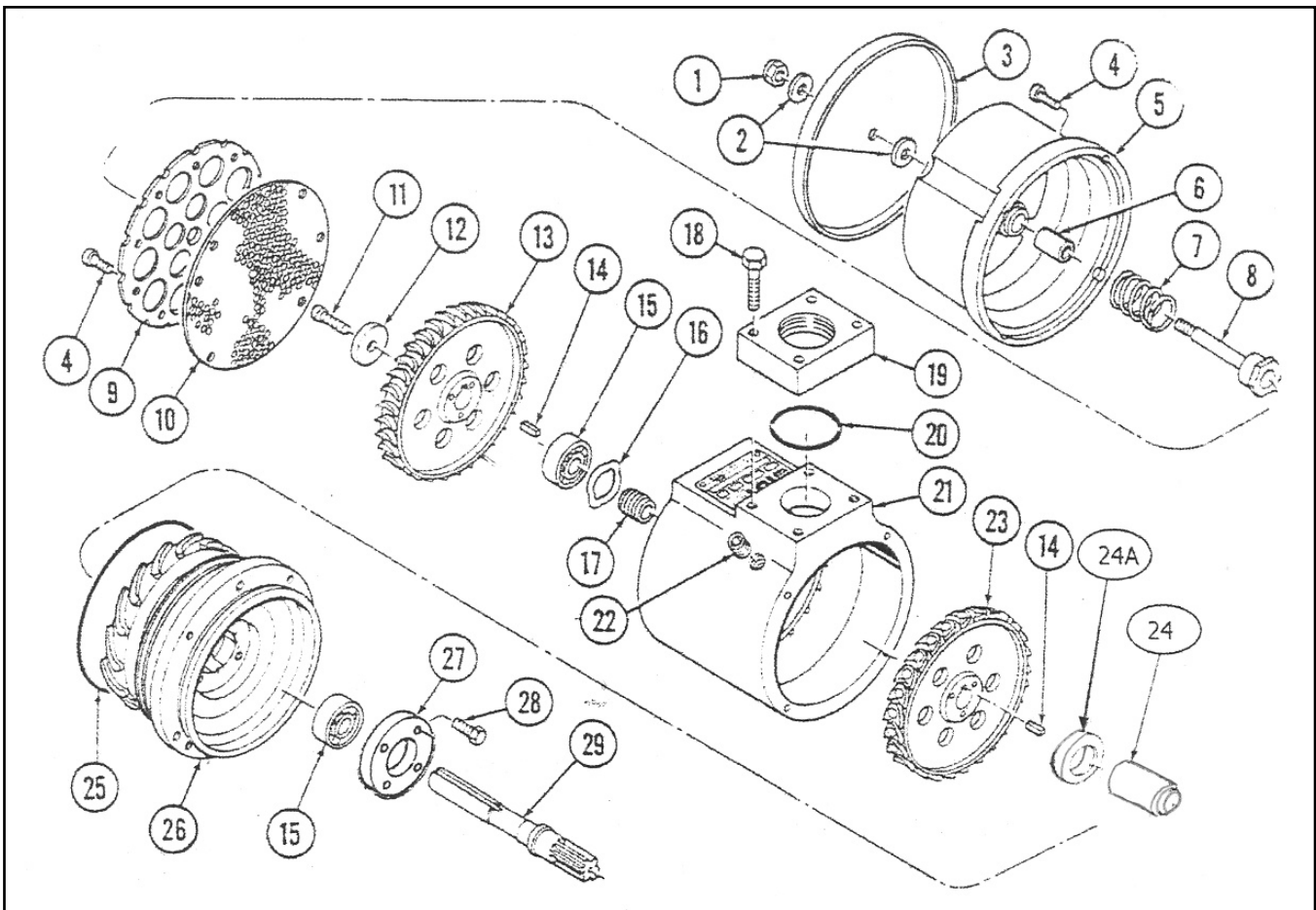

Figure 13. Model T50 Series Turbine Assembly Configured for Air & Natural Gas
(Effective serial #: 0610-0994)